

Read these instructions before commencing installation. Please give these instructions to the owner/occupier after installation to retain for future reference/maintenance.

IP65 IK10 **240V~50Hz 9W/14W/18W**

These fittings are Class II and do not need an Earth, but Earth provision is provided.

Important Information

It is recommended that these luminaires are installed and fitted by a qualified electrician ensuring the installation complies with current wiring regulations & local building control. These products are designed for connection to a 240V~50Hz supply. Any faulty, broken or damaged luminaires should be replaced immediately. KSR will not accept responsibility for any claims arising from a poor installation. Please Note: The limited warranty shall be deemed null and void in the following circumstances: Failure by the installer, end user or any third party to exercise caution to protect any covered product or part from outside damage, adverse temperature (normal operating ambient temperature 0°C - +30°C), humidity conditions, fluctuations in the electrical system or physical abuse as well as failure related to workmanship in the installation of the products or parts.

Important User Advice

Always switch off mains supply before servicing. Do not use Megger or similar high voltage instruments. Due to the fact this luminaire contains electronic components that maybe damaged by high test voltages, they must be disconnected from the circuit before testing. To prevent damage to the driver, do not mix with conventional magnetic ballasts on the same electrical circuit. At the end of life the luminaire is classed as WEEE under directive 2014/30/EU and should be disposed of in accordance with local legislation.

Installation Procedure

Isolate mains supply before installation. Pull the rim off the main body and remove the diffuser / gear tray by turning the rim anti-clockwise. Remove the diffuser / gear tray from the body by unclipping the support strap. Pass supply wires through grommet into the base section, Fix base to the wall or ceiling (if fitting to a wall please ensure the Arrow is pointing UP as shown), ceiling or besa box using adequate fixings with regard to the type of surface. Ensure incoming cables are protected, re-attach the support strap. Terminate wiring as per (Fig. 1), please note an Earth terminal is only supplied to aid the continuation of the Earth circuit. Select switch as Self-test or Non Self-test, Ensure the battery is plugged in (Fig.3) and the plug & play connection between the Emergency Module and Driver is also plugged in. Select LED colour and wattage required using the switches on the LED driver (Fig. 2) Note: Never change the LED colour or wattage with the luminaire powered on as this can damage the luminaire. Set up Corridor function / Microwave sensor via the dip switches (Fig 4. & see page 3). Re-install the diffuser / gear tray by lining up lugs and twisting clockwise to lock in place. Line up the knockouts on the inside of the white rim with the conduit entry points on the base tray and snap on. Turn on the mains supply and test luminaire.

*Please note: Depending on the amount of fittings on a circuit you may have to upgrade the breaker type to avoid nuisance tripping.

Fig.1

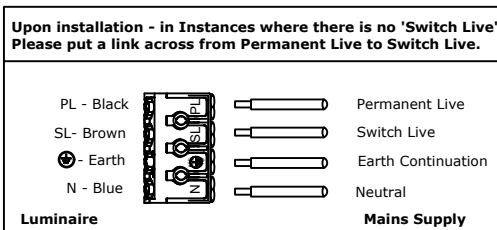
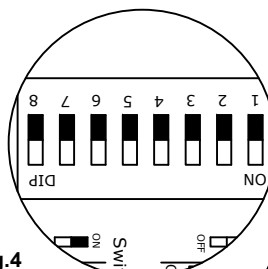

Fig.4

Exploded View - Corridor Function Sensor & MW Dip Switches - Please refer to Page 3 for Settings & Sensor set up info.



White Finish Only

Fig.3

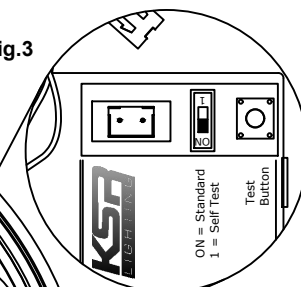

Exploded View Self Test or Non Self test Selector & Battery Connection to be selected / plugged in by the installer.

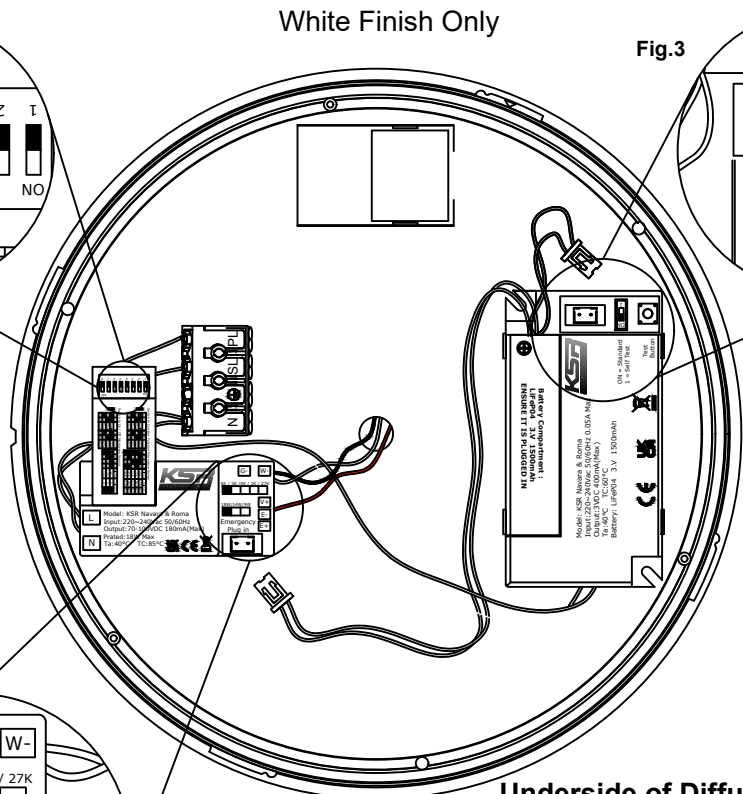

Underside of Diffuser with fixed gear tray.

Fig.2

Exploded View of Wattage & CCT Selector switches located on the end of the driver as shown - Never change these whilst the power is on.

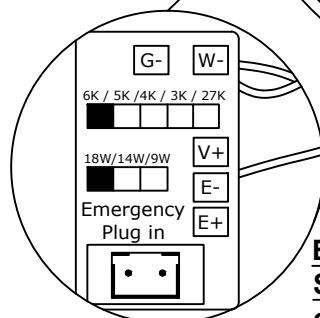

Emergency Connection to the LED Driver - Please ensure this is connected.

CCT	Lumen output				
	2700K	3000K	4000K	5000K	6000K
9W	1015lm	1135lm	1145lm	1135lm	1140lm
14W	1420lm	1670lm	1765lm	1740lm	1700lm
18W	1730lm	2070lm	2135lm	2130lm	2050lm

Other versions are available, Standard & Microwave - Also available are other sizes - @ 260mm Diameter - Roma Mini or @ 420mm Diameter - Roma XL



KSR Lighting Aftersales: 023 92 674343
E-mail: aftersales@ksrlighting.com



Read these instructions before commencing installation. Please give these instructions to the owner/occupier after installation to retain for future reference/maintenance.

IP65 IK10 240V~50Hz 9W/14W/18W

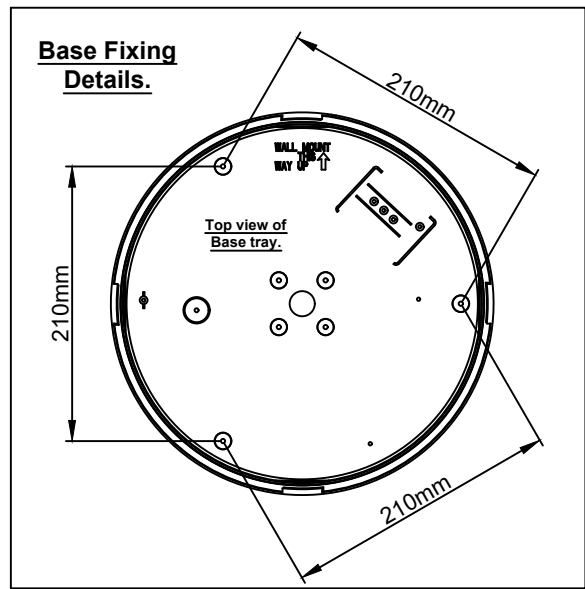
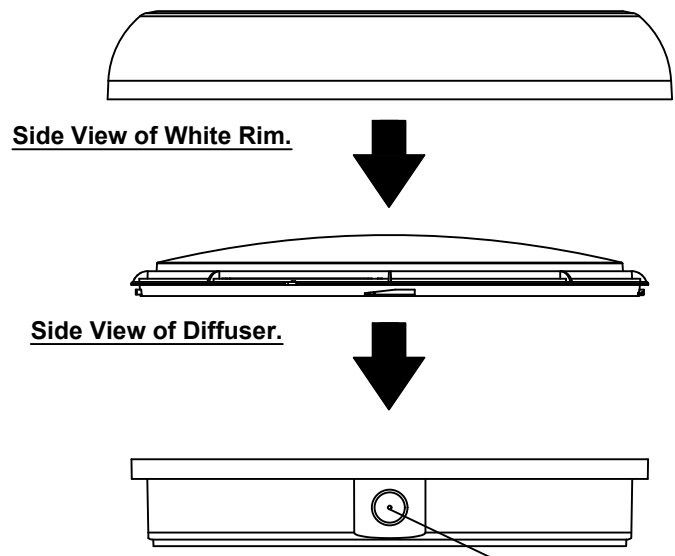
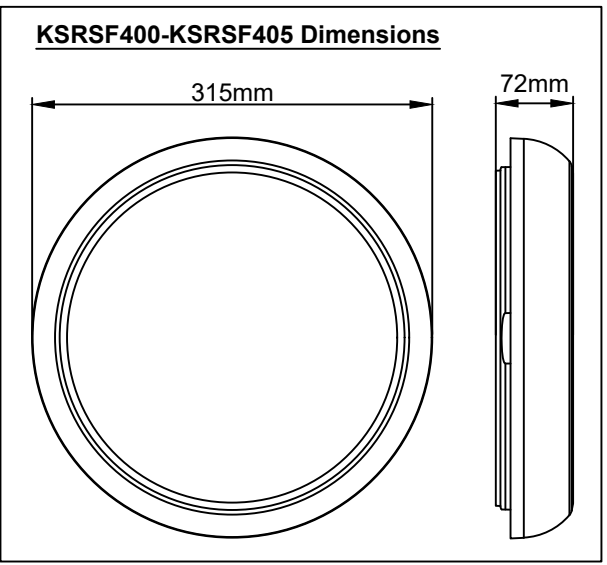

1. Fit the diffuser to the base tray.

Side View of Base tray.

The 4 Knockout points (shown inside) on the rim - to be lined up with the conduit entry points on the base tray, then snap into place.

2. Secure the rim onto the base & diffuser

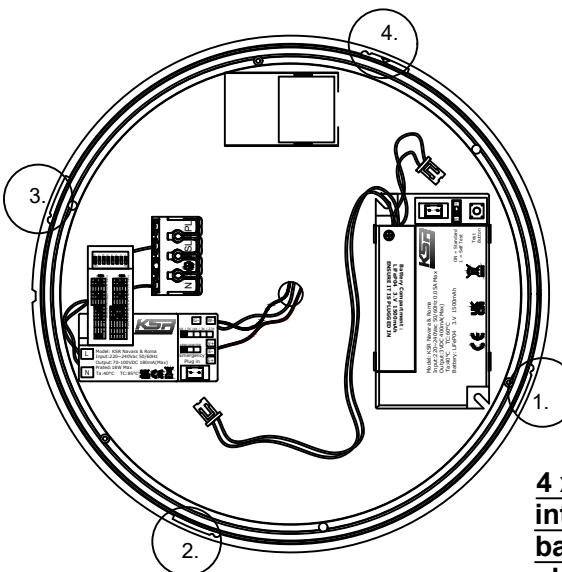

4 x Diffuser lugs lock into place onto the base by rotating clockwise onto the base locator points.

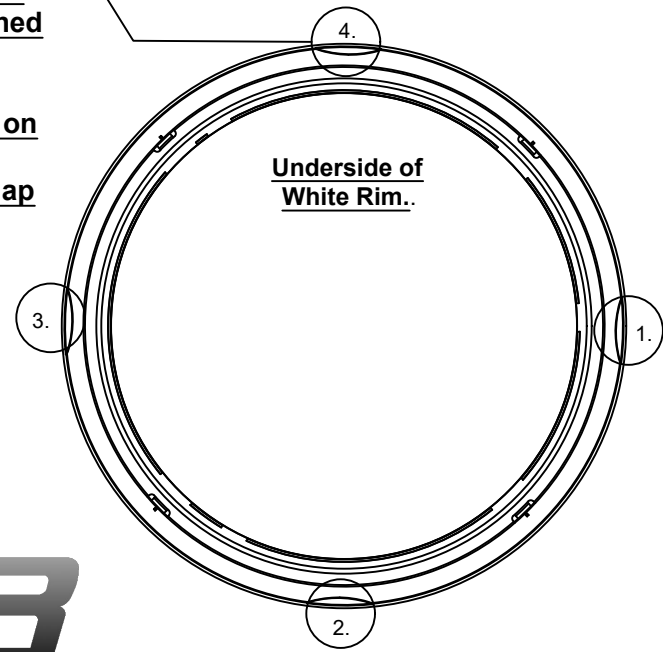
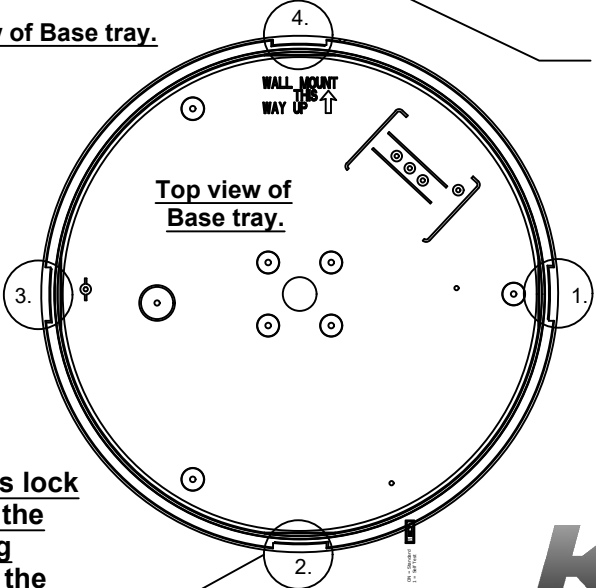



Read these instructions before commencing installation. Please give these instructions to the owner/occupier after installation to retain for future reference/maintenance.

This Corridor Function / Microwave sensor is a motion activated switch, it will turn the light on when movement is detected, then hold the light on for the determined amount of time, after which the light will turn off. This microwave sensor comes with a step-dim feature which is preset by the installer according to their specific requirements

Using the Dip Switches on the sensor, set it up to your preferred Detection area, Hold Time & Daylight level.

Microwave sensors will detect movement through certain materials, if this occurs reduce the detection area until any nuisance triggering stops.

Troubleshooting

Issue	Cause	Solution
The load will not illuminate	Incorrect daylight threshold setting selected	Adjust setting and retest
	Load has failed (driver or LED array)	Replace load
	No mains power detected	Switch on power
The load is permanently illuminated	Continuous movement in the detection area	Check detection area setting
	The lamp (containing sensor) is installed in an area too close to reflective surface, i.e Metal, Glass or Concrete walls.	1. Make sure installation area suitable with at least 30cm space between lamp and surrounding reflective surfaces 2. Reduce Sensitivity (detection area)

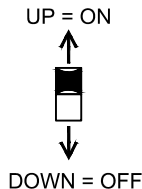

Enlarged view of integral sensor

Switch to Corridor Function Microwave Sensor

5	6	7	Hold Time	Stand-by Time
ON	ON	ON	30s	1min 20%
ON	ON	ON	30s	10min 20%
ON	ON	ON	1min	5min 20%
ON	ON	ON	3min	10min 20%
ON	ON	ON	3min	Disable 20%

Switch to On / Off Microwave Sensor

5	6	7	Hold Time	Stand-by Time
ON	ON	ON	5s	0
ON	ON	ON	1min	0
ON	ON	ON	10min	0

Switch to Corridor Function Microwave Sensor

1	2	3	4	Sensitivity
ON	ON	ON	ON	100%
ON	ON	ON	ON	75%
ON	ON	ON	ON	50%
ON	ON	ON	ON	25%

Switch to On / Off Microwave Sensor

1	2	3	4	Sensitivity
ON	ON	ON	ON	100%
ON	ON	ON	ON	75%
ON	ON	ON	ON	50%
ON	ON	ON	ON	25%

DIP

1	2	3	4	5	6	7	8
ON	ON	ON	ON	ON	ON	ON	ON

Corridor Function Microwave Sensor

1 & 2 = Daylight Sensor

The daylight sensor can be set to bring the light 'on' at specific daylight levels. To have the sensor function in daylight set the Dip Switches to Disable.

1	2	Lux
ON	ON	Disable
ON	ON	50Lux
ON	ON	25Lux
ON	ON	2Lux

3 & 4 = Sensitivity Area

Sensitivity area can be reduced by selecting the combination on the Dip Switches, following the guide as shown here.

3	4	Sensitivity
ON	ON	100%
ON	ON	75%
ON	ON	50%
ON	ON	25%

5, 6 & 7 = Hold Time, Stand by Time & Dimming Level.

Hold time means the time period you would like the light to remain at 100% output once no movement is detected. The Stand by time is the length of time the fitting remains on at the dimmed level of 20%

	5	6	7	Hold Time	Stand-by Time
I	ON	ON	ON	30s	1min 20%
II	ON	ON	ON	30s	10min 20%
III	ON	ON	ON	1min	5min 20%
IV	ON	ON	ON	3min	10min 20%
V	ON	ON	ON	3min	Disable 20%

	5	6	7	Hold Time	Stand-by Time
I	ON	ON	ON	5s	0
II	ON	ON	ON	1min	0
III	ON	ON	ON	10min	0

5, 6 & 7 = Hold Time, Hold time means the time period you would like the light to remain on once no movement is detected.

On / Off Microwave Sensor

1	2	Lux
ON	ON	Disable
ON	ON	50Lux
ON	ON	25Lux
ON	ON	2Lux

3	4	Sensitivity
ON	ON	100%
ON	ON	75%
ON	ON	50%
ON	ON	25%

1 & 2 = Daylight Sensor
The daylight sensor can be set to bring the light 'on' at specific daylight levels. To have the sensor function in daylight set the Dip Switches to Disable.

3 & 4 = Sensitivity Area
Sensitivity area can be reduced by selecting the combination on the Dip Switches, following the guide as shown here.

Microwave Specification

- Mains Input** - 220-240VAC
- Lux Control** - 2 - 50 Lux or Disable
- Time Setting** - Min = 5 Seconds +/- 1 Seconds
Max = 10 Minutes +/- 1 Minute
- Rated Load** - LED = 25W
- Frequency** - 5.8GHz
- Detection Area** - 360 Deg
- Detection Distance** - 6 Metres - Adjustable
- Parasitic Power** - 0.5W
- Installation Height** - 3 Metres

Recommended Installation heights

For Wall mounting the recommended height is 1.5m
For Ceiling mounting the max recommended height is 3m
Detection Zone Max. (D x H): 6m x 3m
Detection Angle. 360°

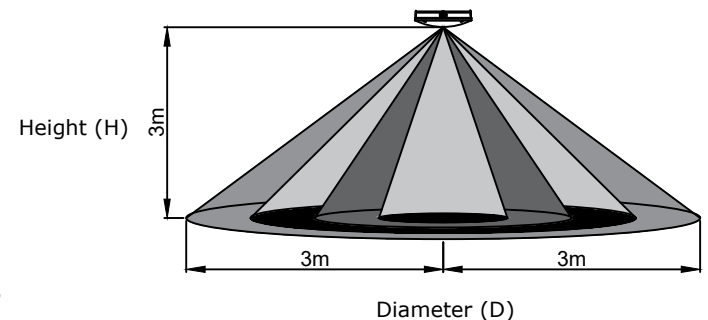

All tests must be undertaken at times of least risk and in accordance with the latest standards as indicated below:

Daily:

LED charge indicators shall be visually inspected for correct operation.

Monthly:

(in addition to the daily check) If automatic testing devices are used, the results of the short duration tests shall be recorded. Test shall be carried out as follows:

1. Switch the luminaire over to emergency mode to operate from the batteries by simulating a failure of supply to the emergency circuit for a period sufficient to ensure correct luminaire operation.

Note: The period of simulation failure should be sufficient for the purpose of this clause whilst minimising damage to the system components e.g lamps. During this period, all luminaires shall be checked to ensure that they are present, clean and functioning correctly. At the end of this test period, the unswitched supply should be restored and any indicator lamp or device should be checked to ensure that is showing that the supply has been restored.

Annually:

If automatic testing devices are used, the results of the short duration tests shall be recorded. For all other systems the monthly inspection shall be carried out and the following additional tests made:

1. Each luminaire shall be tested monthly as above but for its full duration in accordance with the manufacturer's information.
2. The unswitched supply for the luminaire should be restored and any charge indicator lamp or device should be checked to ensure that it shows the unswitched supply has been restored. The charging arrangements should be checked for proper functioning.
3. The date of the test and its results shall be recorded in the system logbook.

A copy of this report must accompany any emergency luminaire returned to KSR Lighting for any reason.



Self Test Emergency Inspection/Testing Instructions

All full duration tests should be where possible be undertaken at times of low risk adjacent emergency luminaires we recommend that you you reset the inbuilt timer or run a manual 30 day test on alternate emergency luminaires to stagger testing times. Once commissioned fill in the date of the first test/install date this will allow the end user to monitor and record subsequent test information on the supplied report. All tests with the exception of the visual inspection will be completed automatically at the relevant times including battery charge condition and lamp status.

Daily:

Visual inspection of the battery charge LED.

Automatic Monthly (Every 30 Days):

(in addition to the daily check) The results of the short duration test shall be recorded.

Automatic Annually (Every 180 & 360 Days):

(in addition to the daily check) The results of the full duration tests shall be recorded.

A copy of this report must accompany any emergency pack returned to KSR Lighting for any reason.

Performance Indicators	
Normal Operation	Red LED off, Green LED Solid
Automatic 30 Day Test	Red LED off, Green LED flashing once a second
Automatic 180/360 Day Test	Red LED off, Green LED flashing twice a second
Manual Simulated Power Failure	Red LED off, Green LED off
Manual 30 Day Test	Red LED off, Green LED flashing once a second
Manual 180/360 Day Test	Red LED off, Green LED flashing twice a second
Manual Fast Test (24 minutes)	Red LED off, Green LED four times a second

Manual Testing - Can only be completed under mains conditions	
Manual Simulated Power Failure	Hold test button until you hear 1 beep
Manual 30 Day Test	Hold test button until you hear 2 beeps
Manual 180/360 Day Test	Hold test button until you hear 3 beeps
Manual Fast Test (24 minutes)	Hold test button until you hear 4 beeps
Abort Test	Hold test button for 1 second
Reset Inbuilt Timer	Hold test button for 15 seconds long beep

Fault Indicators	
Battery/Charging Fault	Red LED flashing once a second, Green LED off, Beeps twice every minute until fault rectified
Lamp Fault	Red LED flashing twice a second, Green LED off, Beeps twice every minute until fault rectified
Failed Duration Test	Red LED solid, Green LED off, Beeps twice every minute until fault rectified

Fault Indicator - **LED SOLID RED**

This means the batteries have been totally depleted and will require a hard reset - This is done by, with the unit still fully powered, unplug the battery connector and plug back in. If this does not resolve the issue, please call KSR Aftersales.



KSR Lighting Ltd, Optimum House, Beeding Close, Southern Cross Trading Estate,
Bognor Regis, West Sussex, PO22 9TS.

KSR Lighting Aftersales: 023 92 674343
E-mail: aftersales@ksrlighting.com

